



## **TZ-V-3 Tri-band Trapped Vertical - Installation Manual**

The TZ-V-3 is a trapped vertical antenna for the 10, 15 and 20m amateur bands. The antenna uses an aluminium radiating section and two traps to permit performance on three frequency bands. All hardware supplied is stainless steel to cope with aggressive environmental conditions except for the mounting U bolts which are optionally supplied at slightly extra cost as stainless steel.

The antenna uses high efficiency coaxial traps which are sealed against the ingress of moisture and surrounded with a PVC cover to protect the traps from rodent and bird attack, a common occurrence

in many locations. Heavy wall tubing is used to provide superior strength and durability.

The antenna has a large bandwidth capable of being tuned for a maximum VSWR of less than 2.0:1 across the whole of the 10m, 15m and 20m bands. The antenna may be ground mounted, mounted on a metallic surface, such as the roof of a house or garage or on a pole or tower with the addition of a radial kit. When mounted on a pole in the clear the antenna is extremely efficient and offers excellent low angle radiation for DX communications.

### **Supplied Equipment**

The following equipment and/or facilities are supplied with the TZ-V-3 antenna:

<b>Radiating element:</b>	Radiating section – Various sleeved aluminium sections.
<b>Traps</b>	(2) Two traps – 10m and 15m resonant.
<b>Adjustment hose clamps</b>	(3) Three stainless steel hose clamps, 32mm, 25mm and 15mm.
<b>Mounting bracket</b>	Aluminium mounting bracket attached to a support pipe or tube.
<b>Mounting hardware</b>	(2) 50mm galvanised steel U bolts.
<b>Radial Kit Mounting</b>	(2) Stainless Steel M6 phillips head screws, flat and spring washers.
<b>Instruction Manual</b>	This document.

### **Optional Equipment**

<b>Radial Kit</b>	(3) Three wire radials supplied terminated with a 6mm eyelet with heatshrink mechanical strengthening at the eyelet. Cut to length for each operating frequency with terminating nylon thimble for attachment of wire/nylon rope. One nylon thimble to be used as an end termination per radial.
<b>Stainless Steel U Bolts</b>	(2) Stainless Steel 50mm U bolts are supplied instead of the two (2) 50mm galvanised U bolts for mounting the vertical on a pipe.

### **Guidance for all installation types**

To assist with corrosion protection for the RF connectors, a layer of plastic insulation tape followed by a layer of self-amalgamating tape (bhtal rubber) tape may be used. The electrical tape assists in making removal of the self-

amalgamating tape easier when maintenance is required. Use drip loops to form a single coil of cable that assists with corrosion protection and provides stress relief for the RF coaxial feeder.

### **Tools Required for Assembly and Tuning.**

The following tools are required to assemble the TZ-V-3 antenna:

- Flat blade screwdriver, M6 allen key (radial kit only)
- 13mm open ended spanner,
- VSWR Meter or antenna analyser.



## Warning Electrocution Hazard

When installing this antenna be sure not to come into contact with overhead electrical power lines which may not be insulated. Contact with uninsulated overhead powerlines whilst installing or operating this antenna may lead to *serious injury* or *death*. DO NOT INSTALL this antenna in a location where mechanical failure of the support or antenna may allow the antenna or support structure to fall onto or come into contact with overhead electrical power lines.

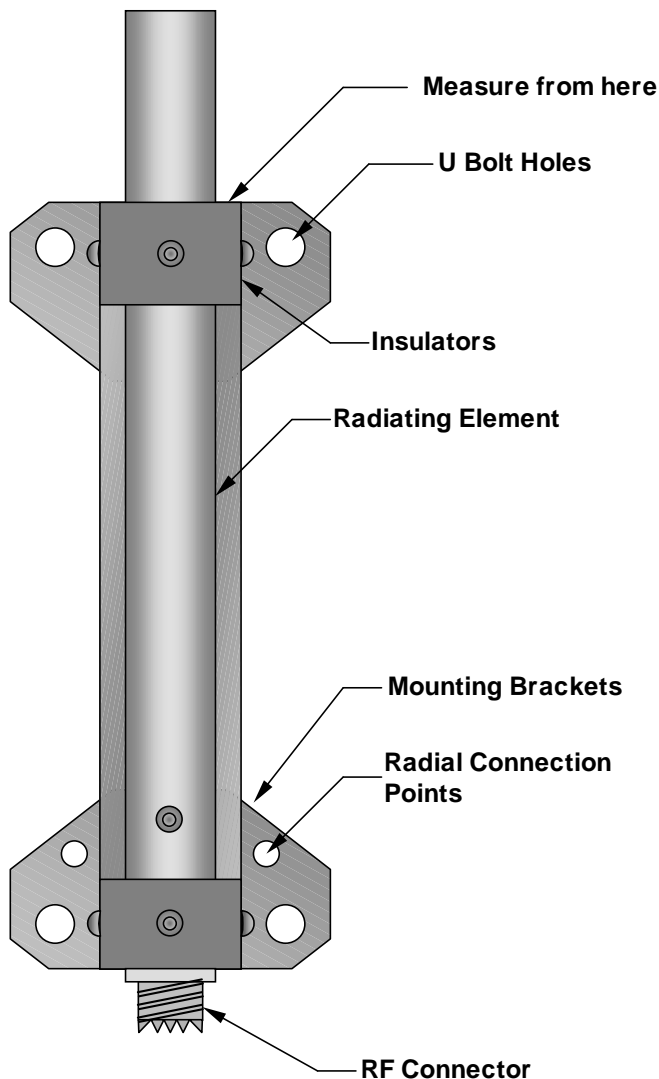

Figure 1 – Bottom Section Detail

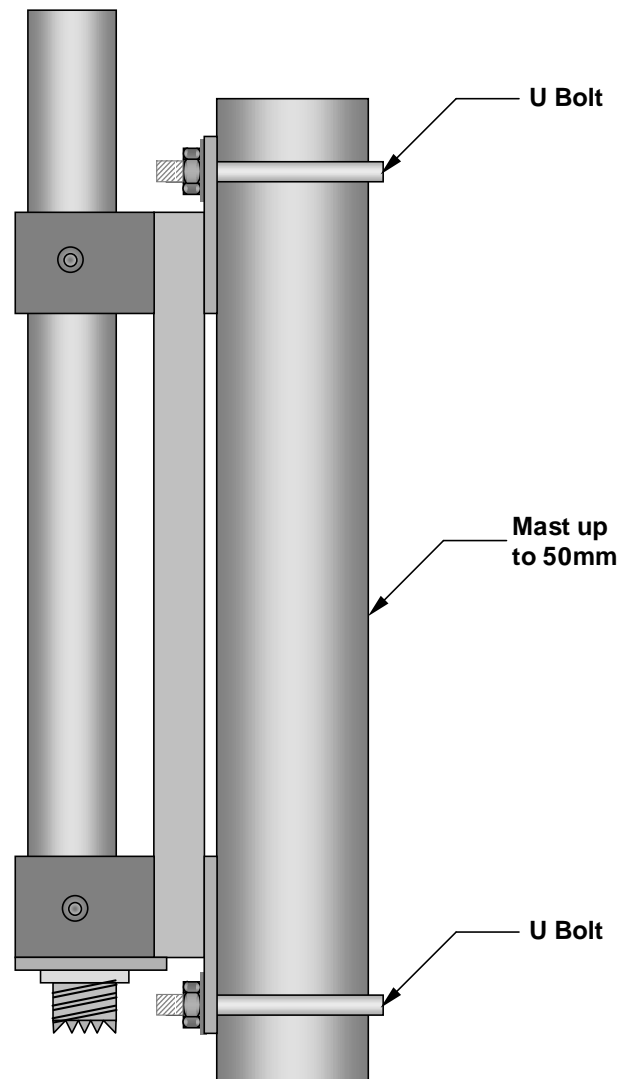
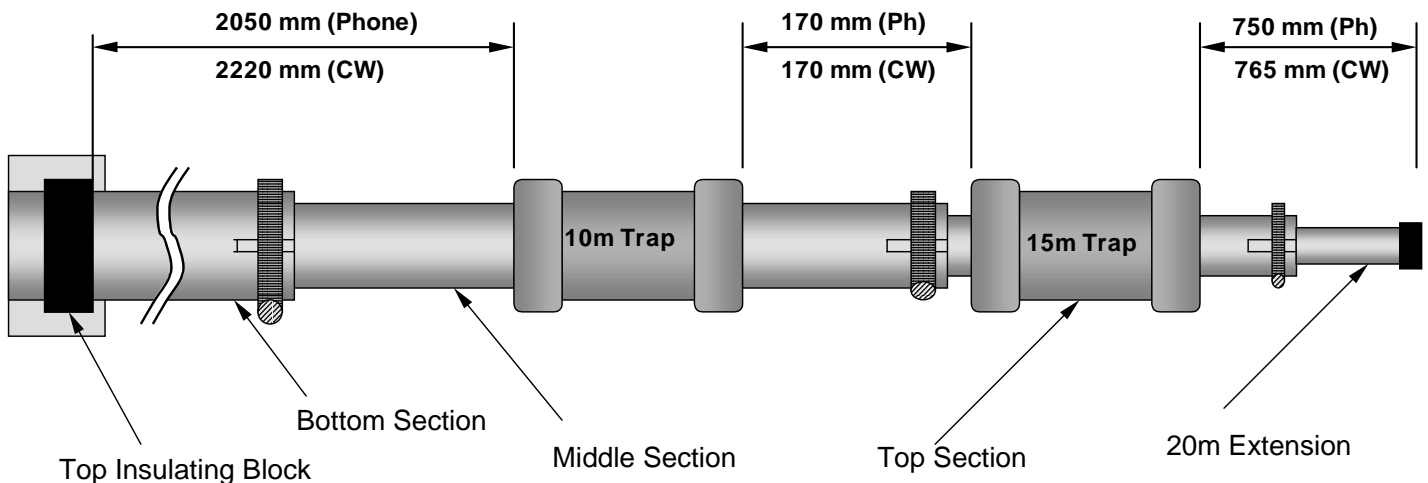

Figure 2 – Mounting Details

### Assembling the antenna.

Locate all the components and check that all hardware has been supplied with your antenna. If any item is missing please contact RippleTech

Electronics for a replacement item, [info@rippletech.com.au](mailto:info@rippletech.com.au) or contact your local agent or supplier.



**Figure 3 – Assembly and Adjustment**

Locate the bottom section of the antenna. This is identified by the mounting hardware/bracket at the base. Locate the 32mm hose clamp (this is the largest one supplied). Place the hose clamp over the end of the bottom section and tighten so that the clamp only just does not move when the section is held vertical.

Locate the top radiating section which contains the 15m trap and the 15mm hose clamp (this is the smallest one supplied). Locate the 20m extension piece which is a tapered tube 12mm ► 10mm aluminium tube. Place the hose clamp over the top end of the 15m trap tubing (end with a slit) and tighten as per the bottom section instructions. Insert the 20m extension piece. Adjust the length of the entire 20m section so that the length of the element from the top edge of the trap to the top of the antenna is in accordance with Figure 3 – Assembly and Adjustment. Use the length described for optimised VSWR for either Phone or CW portions of the 20m band. Tighten the hose clamp fully.

Locate the middle radiating section which contains the 10m trap and the 25mm hose clamp (this is the middle size one supplied). Place the hose clamp over the top end of the 10m trap tubing (end with a slit) and tighten as per the bottom section instructions. Insert the 15m trap and 20m extension

piece into the middle radiating section. Adjust the length of the aluminium tubing between the top of the 10m trap and the base of the 15m trap in accordance with Figure 3 – Assembly and Adjustment. Use the length described for optimised VSWR for either Phone or CW portions of the 15m band. Tighten the hose clamp fully.

Insert the top and middle sections of the antenna into bottom section. Adjust the length of the aluminium tubing between the top of the mounting insulator and the base of the 10m trap in accordance with Figure 3 – Assembly and Adjustment. Use the length described for optimised VSWR for either Phone or CW portions of the 10m band. Tighten the hose clamp fully.

Locate the mounting U Bolts and insert them into the mounting bracket.

If you have ordered the optional radial kit, locate the radials and associated M6 screws. Place the eyelets of two of the radials over one of the tapped radial mount holes. Insert and tighten the M6 screw. Repeat for the remaining radial on the other side of the mounting bracket. The order or selection of radials for each side is not critical.

Assembly of your antenna is now complete.



## Pre-tuning of your TZ-V-3

Prior to erection of the antenna at full height it is advisable to check that the antenna is correctly tuned. Use a VSWR or antenna analyser to check the VSWR of the antenna on each band. For ground mounted installations this step will configure the antenna for final installation. For pole or tower mounting locate the antenna at height of approximately 2m, and extend the radials downward so that they touch the ground at their ends. Support with a brick or other heavy object.

There is no need to earth the radials at the ends. For a roof mounted installation simply earth the antenna as best as possible, use a number of radials lying on the ground or other simulation of the final installation location.

Measure the VSWR of the antenna across each band and note the values at 50 kHz intervals on 15 and 20m and 100 kHz intervals on 10m. Locate the minimum VSWR point and determine if this is acceptable for your type of operating. If necessary alter the lengths of the various sections to achieve the VSWR dip at your preferred frequency. Adjust the bottom section first (10m), middle section second (15m) and the top section (20m) last. There is interaction between these adjustments. Shorten

the lengths to raise the VSWR dip frequencies or lengthen the distances to lower the VSWR dip frequencies.

As a guide the following applies

**10m** A 10mm change in length will adjust the antenna resonant frequency by 100 kHz

**15m** A 10mm change in length will adjust the antenna resonant frequency by 150 kHz

**20m** A 10mm change in length will adjust the antenna resonant frequency by 200 kHz

For instance, if you wish to alter the 10m frequency up by 250 kHz decrease length A by  $250/100 \times 10\text{mm} = 25\text{ mm}$ . Once the 10m section is tuned, measure the 15m VSWR performance, and repeat for length B. Lastly, measure the 20m VSWR performance and repeat for length C.

Note, if you are using your own radials, the length of the radials and/or deployed angles will effect the VSWR and resonance points of your the TZ-V-3. Changing the length or down tilt angle of the radials can affect the VSWR and can be used to obtain a better impedance match. For optimum VSWR the radials should tilt downwards at close to 45°.

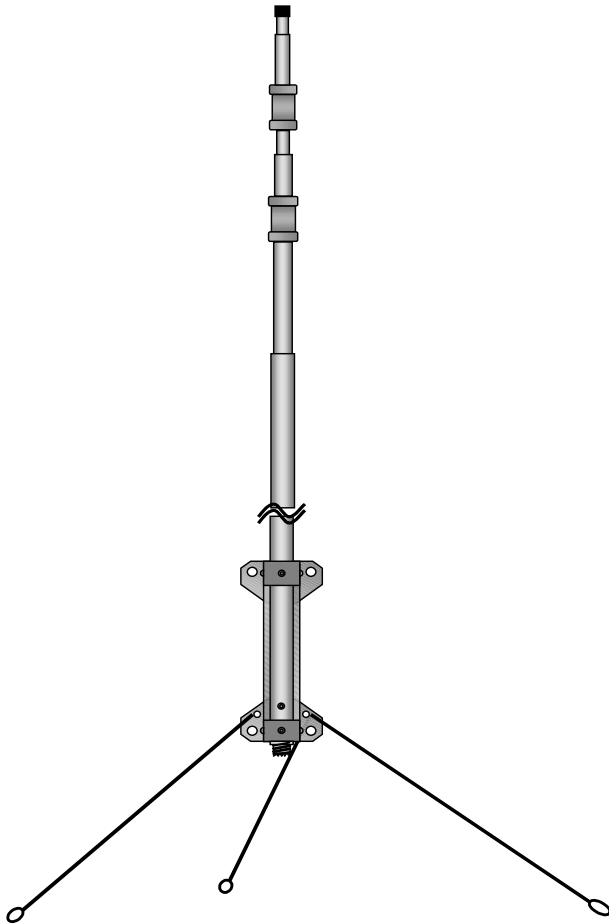

**Figure 4 – Final Configuration**

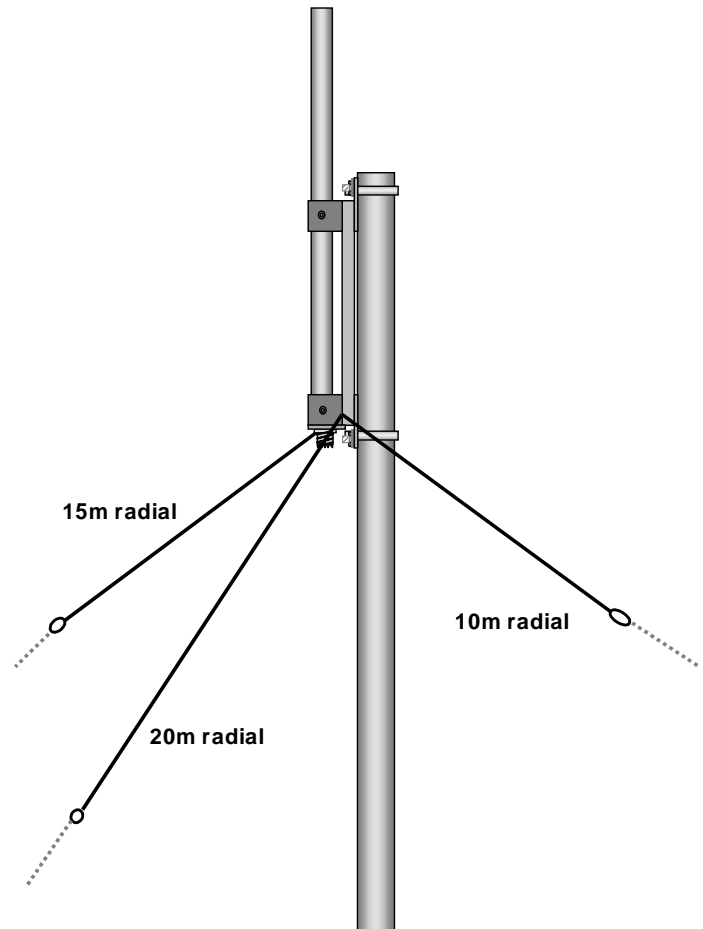

**Figure 5 – Radial Installation Detail**

### **Mounting the TZ-V-3 on the ground**

When mounting the TZ-V-3 on the ground a short stub mast is required. It is advisable to ensure that the stub mast is earthed and is conductive. The stub mast should be inserted at least 500mm deep, preferably 750mm or greater. The coax socket at the base of the antenna should be no more than 100mm above the ground. To ensure good efficiency, at least 4 radials of at least 5m in length should be connected to the stub mast or mounting bracket. Use the pre-tapped M6 holes. For optimum ground mounted efficiency 32 radials of 5m length or greater should be installed. Note that the input

### **Mounting the TZ-V-3 on a roof**

When mounting the TZ-V-3 on a metal structure such as a roof a short stub mast is required, approximately 300mm in length. It is advisable to ensure that the stub mast is conductive and connected to the metal structure. The coax socket at the base of the antenna should be no more than

impedance of a quarter wave vertical is approximately 37.5 ohms when fed against a perfect conductor. If the antenna has a ground resistance of 15 ohms then the antenna input impedance will be very close to 50, i.e. a VSWR of 1:1. However, significant power will be dissipated in the ground. By adding radials to your antenna, the VSWR may be degraded but the operating efficiency of your antenna will be improved. With an effective ground radial system, the VSWR of the TZ-V-3 would be close to 1.5:1 at resonance.

100mm above the structure. No radials are required if the metal surface is at least 1m<sup>2</sup>. Ensure that the method used to secure the stub mast to the metal structure is sufficient to withstand the bending moment applied by the antenna under strong wind conditions.



## Mounting the TZ-V-3 on a pole

When installed on a pole or tower the TZ-V-3 requires a ground plane. This is best achieved using the optional radial kit supplied by RippleTech Electronics. If the antenna is mounted directly above a large yagi array this may be substituted for a ground plane as long as the mount point is less than 10cm from the boom of the beam.

When mounted on a pole the radials (kit or your own) should be connected as previously described. The radial should be angled down from the antenna at angle of between 30° and 50°, preferably 45°. In plan view the radials should be separated from each other by approximately 120°, i.e. evenly spaced around the antenna, in order to provide an omni-directional radiation pattern. Slight departures from

120° separation will not drastically effect the antenna performance.

The radial lengths should be approximately ¼ wavelength long. Note that the velocity factor of the wire used is significant. For bare copper or stainless steel wire an approximate formulae is:

$$\text{Radial length} = (300/\text{freq}) \times 0.25 \times 0.96$$

For PVC insulated wire use:

$$\text{Radial length} = (300/\text{freq}) \times 0.25 \times 0.92$$

**Attention: The copper radials should not be used as guys, since their strength is insufficient for this purpose.**

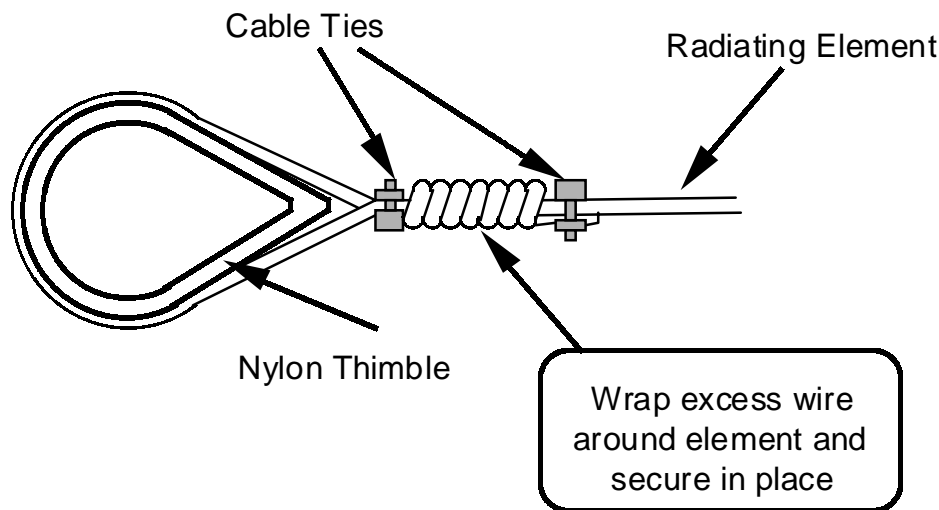

**Figure 6 – Radial connection to support ropes**

Change Required	Option One
To Lower Resonant Frequency	Lengthen dimension A, B or C
To Raise Resonant Frequency	Shorten dimension A, B or C
To Raise Impedance	Lower the radial ends lower
To Lower Impedance	Raise the radials more towards horizontal.

**Table 1 - VSWR adjustment Options**



## Specifications

<b>Type</b>	Trapped Vertical (1/4 wavelength)		
<b>Frequency Range</b>	10m, 15m, 20m .		
<b>Bandwidth</b>	10m - 2500 kHz, 15m - 500 kHz, 20m, - 500 kHz (2.0 : 1 VSWR limit).		
<b>Input Impedance</b>	Nominally 50 ohms.		
<b>VSWR Minimum</b>	Sloping Radials	Over flat G.P	
	10m 1.2:1	10m 1.5:1	
	15m 1.5:1	15m 1.7:1	
	20m 1.2:1	20m 1.4:1	
<b>Radiation polarisation</b>	Vertical		
<b>Gain</b>	10m- 2.4 dBi,	15m - 1.8 dBi,	20m - 1.2 dBi
<b>Directivity</b>	Omni-directional		
<b>Front to Back</b>	Not Applicable.		
<b>Power Handling</b>	1000 Watts PEP		
<b>Total Weight</b>	4.5 kg.		
<b>Overall Length</b>	3.62 m – 3.75m		
<b>Wind Survival</b>	150 km/h		

## Special Notes – Ingress of water into the trap covers

The antenna traps are sealed both internally and externally. However, from time to time, or if the antenna is subject to a combination of high rainfall and winds causing vibration, one or more seals may fail. The external PVC cover for each trap is provided only as protection against bird attack. In the event a trap outer cover seal fails, water may become trapped inside the trap cover. This will produce a high VSWR or moderate change in VSWR for one or all of the frequency bands in use.

The ingress of moisture usually will not result in damage to the trap itself, however the water will electrically connect the top and bottom aluminium sections which will prevent the trap from operating correctly, unless the water is removed.

To repair a trap which has not been electrically damaged, disassemble the antenna and whilst gently shaking each trap, listen for “sloshing” water within the trap.

If the trap is filled with water, drill two (2) small holes approximately 2 - 3mm in diameter in the lower end cap of the trap. Use a battery powered drill to prevent any chance of electrical shock when the water is released from the trap. **Ensure that the drill penetrates only 3 or 4mm into the trap cavity to prevent damage to the internal circuitry of the trap.**

You may wish to re-seal the trap using a neutral cure clear silicon sealant, or leave the holes in place to allow water to drain from the base of the trap.

The coaxial cable traps are sealed internally, however if high power has been used with the trap full of water, arcing may have occurred. In such an instance, removing the water from the trap will not return the trap to a serviceable condition and the trap will require replacement with a new item.